

SPR-P6-XXX-COM-M-BF

PERFORMANCE 6 SOLAR PANEL

535-550 W | Up to 21.1% Efficient



Ideal for commercial applications



Framed glass-glass



Bifacial energy generation

Enhanced Power Density

With high efficiency, LeTID/LID-resistant solar cells (G12, 210mm), bifacial energy capture, a lower temperature coefficient, and front-side conductive wires that support increased current collection, SunPower Performance panels are uniquely engineered to deliver more lifetime energy over standard solar panels.

Proven Reliability

A proprietary shingled-cell design maximises durability in all types of weather conditions—including reinforced cell connections that withstand the stresses of daily temperature swings, redundant electrical paths that alleviate the impact of cell cracks, and an advanced electrical architecture that is more resilient to the effects of shade and mitigates hot-spot formation.



SunPower Complete Confidence Warranty

Each SunPower Performance panel is manufactured with the absolute confidence to deliver more energy and greater reliability over time—and backed for 25 years by one of the industry's most comprehensive warranties.

Product and power coverage	25 / 25 Years
Year 1 minimum warranted output	98.0%
Maximum annual degradation	0.45%



Learn more about the SPR-P6-XXX-COM-M-BF
sunpower.maxeon.com

Performance 6 POWER: 535-550 W | EFFICIENCY: Up to 21.1%

Electrical Data, Front STC Characteristics ¹				
	SPR-P6-550-COM-M-BF	SPR-P6-545-COM-M-BF	SPR-P6-540-COM-M-BF	SPR-P6-535-COM-M-BF
Nominal Power (P _{nom})	550 W	545 W	540 W	535 W
Power Tolerance	+3/0%	+3/0%	+3/0%	+3/0%
Panel Efficiency	21.1%	20.9%	20.7%	20.6%
Rated Voltage (V _{mpp})	39.5 V	39.3 V	39.1 V	38.8 V
Rated Current (I _{mpp})	13.92 A	13.87 A	13.81 A	13.79 A
Open-Circuit Voltage (V _{oc}) (+/-3%)	47.6 V	47.4 V	47.2 V	47.0 V
Short-Circuit Current (I _{sc}) (+/-3%)	14.82 A	14.81 A	14.80 A	14.79 A

Bifacial Gain ²				
P _{max} with 5% Bifacial Gain	578 W	572 W	567 W	562 W
I _{sc} with 5% Bifacial Gain	15.56 A	15.55 A	15.54 A	15.52 A
P _{max} with 10% Bifacial Gain	605 W	600 W	594 W	589 W
I _{sc} with 10% Bifacial Gain	16.30 A	16.29 A	16.28 A	16.26 A
P _{max} with 20% Bifacial Gain	660 W	654 W	648 W	642 W
I _{sc} with 20% Bifacial Gain	17.78 A	17.77 A	17.76 A	17.74 A

Mechanical Data	
Impact Resistance	25 mm diameter hail at 23 m/s
Solar Cells	Monocrystalline PERC
Glass	2.0 mm, heat strengthened glass
Junction Box	IP-68, 3 bypass diodes
Connector	Renhe RHC2 or Zerun Z4S or Stäubli Evo2
Weight	32.4 kg
Max. Load ²	Wind: 2400 Pa, 245 kg/m ² front & back Snow: 5400 Pa, 550 kg/m ² front
Frame	Silver anodized aluminum alloy

Electrical Data	
Bifaciality (φP _{max})	70% +/-10%
Maximum System Voltage	1500 V IEC
Temperature	-40°C to +85°C
Maximum Series Fuse	25 A
Power Temp. Coef.	-0.34% / °C
Voltage Temp. Coef.	-0.26% / °C
Current Temp. Coef.	0.05% / °C

Tests And Certifications	
Standard Tests	IEC 61215, IEC 61730 Rated to 1500 V
Fire Rating	Class C (IEC 61730)
Quality Certs	ISO 9001:2015, ISO 14001:2015
EHS Compliance	ISO 45001-2018, Recycling Scheme
Ammonia Test	IEC 62716
Dust and Sand	IEC 60068-2-68
Salt Spray Test	IEC 61701 (maximum severity)
LeTID Test	TUV 2fg 2689/04.19 (LeTID Detection)
PID Test	IEC 62804

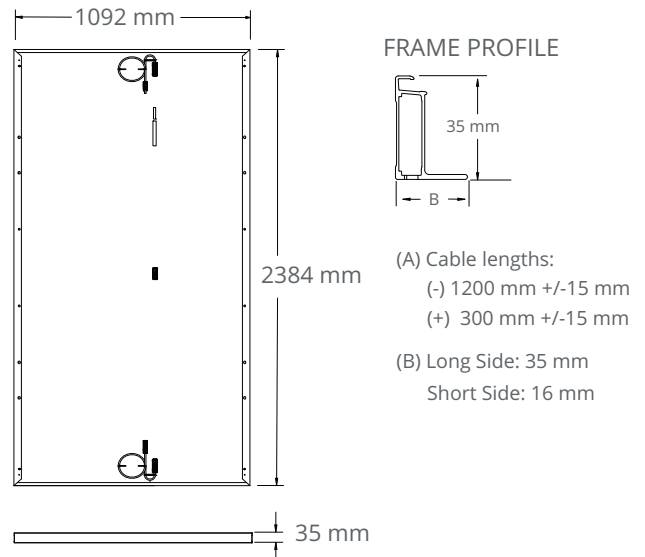

Please read the safety and installation instructions.
 Visit www.sunpower.maxeon.com/int/PVInstallGuideIEC
 Paper version can be requested through
techsupport.ROW@maxeon.com

1 Standard Test Conditions (1000 W/m² irradiance, AM 1.5, 25° C). NREL calibration Standard: SOMS current, LACCS FF and Voltage.

2 The additional gain from the back side of the panel compared to the power of the front side of the panel at the standard test conditions. It depends on mounting (structure, height, tilt angle etc.) and albedo of the underlying surface.

3 Safety factor 1.5 included.

Designed in U.S.A.
 Assembled in China
 Specifications included in this datasheet are subject to change without notice.
 ©2022 Maxeon Solar Technologies. All Rights Reserved.
 View warranty, patent and trademark information at maxeon.com/legal.

SUNPOWER
 FROM MAXEON SOLAR TECHNOLOGIES